

**REGISTRY OF RADIOACTIVE SEALED SOURCES AND DEVICES
SAFETY EVALUATION OF DEVICE
(AMENDS IN ITS ENTIRETY)**

NO.: NC-646-D-128-S

DATE: March 20, 2008

PAGE: 2 of 9

DEVICE TYPE: Asphalt Content Gauge

DESCRIPTION:

The Models 3241-C and 3241-G Asphalt Content Gauges are portable gauges designed to measure the asphaltic tar content in paving materials. The design of these devices is based on the principal of neutron thermalization via collisions with atoms of similar mass and incorporates a doubly-encapsulated neutron-emitting Americium 241:Beryllium radioactive source and a series of four (4) Helium-3 detector tubes. The Model 3241-C gauge utilizes either a 100 mCi (nominal) source or a 300 mCi (nominal) source. The 3241-G utilizes only the 100 mCi (nominal) neutron source. The device operation can be described as follows: fast neutrons, emitted from the source, traverse the test sample that has been placed inside the enclosed test chamber and are subsequently slowed down (thermalized) by collisions with Hydrogen atoms in the test material. The thermal neutrons are then detected by the Helium-3 detectors and counted over a specified time period. Due to the inability of these detectors to detect fast neutrons, the number of thermalized neutrons counted is directly proportional to the number of hydrogen atoms present in the sample. The accompanying electronics then processes the count numbers and calculates the asphaltic tar content using operator-supplied information (*i.e.*, mass of sample and calibration data).

The engineering of the devices is based on a sealed source composed of either a 100 mCi (nominal) or 300 mCi (nominal) mixed sample of Americium 241 oxide and Beryllium in "special form." **The three approved sources are described in the table below:**

	AMN.V340 (100 mCi)	AMN.V339 (300 mCi)	3021-2 (100 mCi)
ANSI/ISO Classification	ANSI-77C65545	ANSI-77C65545	ISO/99/C63433
Min. Neutron Yield (η/sec)	2.2 – 3.2 x 10⁵	7.5 - 9.5 x 10⁵	2.2 – 3.2 x 10⁵
Special Form Certificate*	USA/620/S	USA/620/S	USA/0426/S-96
For use in Model No.:	3241-C & 3241-G	3241-C (only)	3241-C & 3241-G

** See "Limitations or Other Considerations of Use" for additional information regarding SFC for older 3241 gauges.*

Each source is assigned a unique serial number from the manufacturer and the capsule contains other markings (e.g. nuclide and activity) which vary by manufacturer. The sealed source is secured in a fixed, permanent position in the device with no "on-off" mechanism or source shutter. The overall outside dimensions of the device (excluding controller) measure 36 cm (length) x 28 cm (width) x 27 cm (height).

REGISTRY OF RADIOACTIVE SEALED SOURCES AND DEVICES
SAFETY EVALUATION OF DEVICE
(AMENDS IN ITS ENTIRETY)

NO.: NC-646-D-128-S

DATE: March 20, 2008

PAGE: 3 of 9

DEVICE TYPE: Asphalt Content Gauge

DETAILS OF CONSTRUCTION:

The models 3241-C and 3241-G are constructed from four basic materials: aluminum, cadmium, high-density polyethylene and stainless steel. High density polyethylene is used in the construction of the source holder, the barrier surrounding the source housing in the top of the device, the sample chamber walls (thickness: 15.9 mm) and floor (thickness: 15.2 mm – 25.4 mm), and the base stand (thickness: 25.4 mm). Cadmium (thickness: 0.4 mm) is used to shield the outside of the polyethylene source housing barrier and to line the inside walls of the device in such a fashion that no neutron emitted from the sealed source could leave the device without passing through at least one thickness of cadmium.

Stainless steel (thickness: 1.2 mm) is used in the bottom of the sample chamber to cover the aluminum housing over the detectors, giving increased shielding in the direction of the emitted beam. Finally, aluminum is used as the main construction material in the fabrication of the rest of the device. This includes the device walls, top, and bottom; sample chamber interior faces; and other similar structures exterior to the device.

A circular hole (19.1 mm in diameter) is cut into the top interior face plate of the chamber to act as the neutron beam exit port. The overall design and construction of the devices render the source housing immovable and access to the radioactive materials highly restricted. The devices would have to be disassembled in entirety to gain access to the sealed source. Furthermore, the small sample chamber volume precludes an operator from inadvertently being exposed.

3241-C Specifics:

In this gauge model, the sealed source is inserted into a 5.72 cm long cylindrical aluminum source housing (o.d. – 2.54 cm & i.d. 1.59 cm) and positioned in the housing by a polyethylene source holder that fills the void space. The source capsule is secured in the housing by means of a threaded plug/cap which is then covered with a "Caution –Radioactive Material" label. Immediate source shielding is provided by a high-density polyethylene domed barrier wrapped with cadmium. The shielded source, holder, housing, and barrier are then attached to the internal aluminum structure of the device with two (2) #6 steel screws. The internal dimensions of the sample chamber measure 25.0 cm (length) x 19.4 cm (width) x 11.1 cm (height).

3241-G Specifics:

In this gauge model, the sealed source is inserted into a 4.45 cm long cylindrical aluminum source housing (o.d. – 2.54 cm & i.d. – 1.59 cm) and positioned in the housing by a 3.01 cm long polyethylene source holder. The source capsule is secured in the housing by means of a threaded plug/cap which is then covered with a "Caution – Radioactive Materials" label. Immediate source shielding is provided by a high-density polyethylene domed barrier wrapped with cadmium. The shielded source, holder, housing, and barrier are then attached to the internal aluminum structure of the device with two (2) #6 steel screws. The reduction in size of the source housing and barrier was engineered into the gauge to increase the internal counting volume of the sample chamber. The internal dimensions of the sample chamber measure 25.0 cm (length) x 19.4 cm (width) x 12.7 cm (height).

**REGISTRY OF RADIOACTIVE SEALED SOURCES AND DEVICES
SAFETY EVALUATION OF DEVICE
(AMENDS IN ITS ENTIRETY)**

NO.: NC-646-D-128-S

DATE: March 20, 2008

PAGE: 4 of 9

DEVICE TYPE: Asphalt Content Gauge

LABELING:

The 3241-C and 3241-G gauges are labeled in accordance with 15A NCAC 11 .1626. The labels contain the radiation symbol, isotope, activity, model number, serial number, name and address of manufacturer/distributor, and the words "CAUTION-RADIOACTIVE MATERIAL."

The Model 3241-C in the transport case qualifies as a "Yellow II" type package with the following transport indices (TI): TI = 0.4 (300 mCi source) and TI = 0.2 (100 mCi source). The model 3241-G in the transport case qualifies as a "Yellow II" type package with a TI = 0.2 (100 mCi source). The transport cases are thus labeled on two (2) opposing sides as such: along with the US DOT 7A Type "A" label and the manufacturer's label showing the name and address of the manufacturer, the device model and serial number.

DIAGRAM:

Attachments 1 and 2 of this registry certificate contain drawings of the 3241-C and 3241-G respectively and their Type A containers showing the approximate locations of the sources and the orientations used in the radiation profiles of the gauges.

CONDITIONS OF NORMAL USE:

Both of these gauge models are designed to be used by trained personnel to measure the asphaltic tar content of paving materials at the construction site. The user will normally be near the device only for the time period necessary to set up the gauge, load the samples into the gauge, perform the measurement, and unload the samples from the gauge. The frequency of this operation is dependent upon the number of samples to be examined and the number and length of the irradiation times. In addition, a six (6) foot interface cable is used to connect the control unit and sample chamber thus allowing the user to position the control unit several feet from the sample chamber. The source capsule has a recommended working life of fifteen years. The operator's controller does not have to be returned with the chamber as no calibration of the electronics is necessary.

The device is designed for the following environments:

Operating temperature -10°C to 70°C ambient

Pressure Atmospheric

Vibration Ranges from zero to mild (tested @ a displacement of 0.1" @ 12.5 Hz)

Corrosion Ranges from zero to corrosive

Fire +125°C (to melt the source housing high density polyethylene barrier)

**REGISTRY OF RADIOACTIVE SEALED SOURCES AND DEVICES
SAFETY EVALUATION OF DEVICE
(AMENDS IN ITS ENTIRETY)**

NO.: NC-646-D-128-S

DATE: March 20, 2008

PAGE: 5 of 9

DEVICE TYPE: Asphalt Content Gauge

PROTOTYPE TESTING:

The Model 3241-C gauge underwent prototype testing for mechanical, structural and radiological integrity using measurement methodologies and testing procedures found in ANSI Standard N43.8 – 1979. This prototype testing included: stray radiation measurements of gamma dose rates at 5 cm, 30 cm, and 100 cm and neutron dose rates at 30 cm and 100 cm for the gauge in both the “on” and “off” configuration; testing of the gauges’ safety features at room temperature, at an elevated use temperature of 105°C, and at a decreased use temperature of -40°C; a leak test of the radioactive source after the safety feature/temperature testing; and an engineering evaluation of the likelihood of source retention in the source housing following a severe accident involving fire. The results of the testing showed: (1) no safety feature failure or stray radiation increase over the range of temperatures tested; (2) no loss of radioactive materials from the sealed source; and (3) no loss of the sealed source from the source housing in the accidents where the gauge temperature does not exceed 125°C. The results of the prototype testing support the assignment of an ANSI standard rating of ANSI-54-164-164-R1 for the Model 3241-C gauge. **Based on the ISO 2919:1999 rating of C63433 for the Model 3021-2 source, the ANSI rating for the gauge should not change.**

EXTERNAL RADIATION LEVELS:

See Attachment 3 for 3241-C (100 mCi) Radiation Profile

See Attachment 4 for 3241-C (300 mCi) Radiation Profile

See Attachment 5 for 3241-G (100 mCi) Radiation Profile

QUALITY ASSURANCE AND CONTROL:

Troxler Electronic Laboratories maintains a quality assurance and control program which has been deemed acceptable for licensing purposes by the North Carolina Radiation Protection Section. A copy of the program is on file with the Radiation Protection Section.

LIMITATIONS AND/OR OTHER CONSIDERATIONS OF USE:

Distribution: These gauges will be distributed as a specifically licensed device in accordance with the requirements of section .0300 of 15A NCAC 11 and/or applicable regulations of the NRC or an Agreement State. This shall not preclude the exportation of this device to a foreign entity following the applicable regulations.

**REGISTRY OF RADIOACTIVE SEALED SOURCES AND DEVICES
SAFETY EVALUATION OF DEVICE
(AMENDS IN ITS ENTIRETY)**

NO.: NC-646-D-128-S

DATE: March 20, 2008

PAGE: 6 of 9

DEVICE TYPE: Asphalt Content Gauge

LIMITATIONS AND/OR OTHER CONSIDERATIONS OF USE (continued):

Installation and Removal: These gauge models are designed for simple set-up and removal by radiologically trained personnel. The set-up and removal of the device shall be performed following the applicable written instructions provided in the accompanying "Manual of Operation and Instruction." The device components (controller, chamber, and optional printer) shall be unpacked and placed in position and then connected together by their cables. Upon initial receipt of the gauge, the chamber lock and key shall be tested. The packing, shipping and radiological surveying of a device to be returned to the manufacturer or another specifically licensed recipient shall be carried out so as to be in compliance with the applicable regulations pursuant to 49 CFR 173.

Leak Testing: The device shall be leak tested by the user following the instructions in the "Manual of Operation and Instruction" at intervals not to exceed twelve (12) months using techniques capable of detecting the presence of 0.005 microcurie of removable contamination. If the level of contamination exceeds this limit, the device shall be returned to Troxler Electronic Laboratories, Inc. for repair/disposal. Please note, Troxler Electronic Laboratories maintains a customer leak test service.

Servicing: These gauge models contain no user-serviceable components. The controller, containing the scaler and associated data analysis electronics, will generally be returned to a Troxler Service Center for all servicing. Servicing of the sample chamber which holds the radioactive source, including but not limited to source replacement, general servicing, repair, and/or disposal, shall be done by the manufacturer or another appropriately licensed facility.

Dosimetry: All authorized users of these gauges should wear personnel dosimetry (film badges or TLD) in accordance with NRC or Agreement State regulations. The dosimetry used should be developed and the results reported in accordance with statements and/or conditions in the licensee's specific license. Please note, Troxler Electronic Laboratories maintains a NVLAP certified dosimetry program.

Operating and Safety Instructions: These devices shall be operated following the written operating and safety instructions given in the device manual, "Manual of Operation and Instruction."

Training: Use of these gauge models is limited to individuals who have completed the manufacturer's or equivalently approved training class in the basic principles of radiation safety and the proper use of these gauges.

Reviewer Note: This registration sheet and the information contained within the references shall not be changed without the written consent of the North Carolina Radiation Protection Section, Radioactive Materials Branch.

**REGISTRY OF RADIOACTIVE SEALED SOURCES AND DEVICES
SAFETY EVALUATION OF DEVICE
(AMENDS IN ITS ENTIRETY)**

NO.: NC-646-D-128-S

DATE: March 20, 2008

PAGE: 7 of 9

DEVICE TYPE: Asphalt Content Gauge

LIMITATIONS AND/OR OTHER CONSIDERATIONS OF USE (continued):

Special Form Certificate Information:

Some older 3241 Series gauges may contain sources that are no longer certified as Special Form. Americium-241 sources that are not certified as Special Form cannot be shipped as Normal Form. The table below shows the source codes and serial number ranges that are affected.

Troxler Electronic Laboratories has been granted a Special Permit by the US Department of Transportation (DOT-SP 14287) that authorizes one-time shipment of these sources for disposal only. This Special Permit imposes a number of conditions and requirements on the shipper. Troxler has prepared an information package that fully describes these conditions and provides shipping instructions. Licensees should contact Troxler directly for this information.

Gauges cannot be shipped to Troxler without a Return Goods Authorization (RGA) number issued by Troxler. Additional information can be found on Troxler's website (www.troxlerlabs.com/RADSAFETY/specialtransport.shtml).

<u>Source Code</u>	<u>Serial Numbers</u>	<u>Nuclide</u>	<u>Activity</u>	<u>Shipment Type</u>
55	<8132 or between 17978 & 18080	Am-241	100 mCi	Special Permit
60	All Serial Numbers	Am-241	300 mCi	Special Permit

DOCUMENTATION:

The documentation enclosed with the device upon shipment to the user shall include the following:

1. Manual of operation and instruction,
2. Special form certificate,
3. Type "A" package testing results,
4. A copy of the final leak test results made prior to packaging,
5. Bill of lading,
6. An emergency response information sheet,
7. Troxler gauge certificate,
8. Troxler transportation guide.

**REGISTRY OF RADIOACTIVE SEALED SOURCES AND DEVICES
SAFETY EVALUATION OF DEVICE
(AMENDS IN ITS ENTIRETY)**

NO.: NC-646-D-128-S

DATE: March 20, 2008

PAGE: 8 of 9

DEVICE TYPE: Asphalt Content Gauge

SAFETY ANALYSIS SUMMARY:

The design of the Models 3241-C and 3241-G make these gauges safe to operate by personnel trained in the proper use of these gauges and radiological safety. The inherent safety features of the devices include: (1) a sealed source, doubly encapsulated and welded closed; (2) the use of cadmium shielding throughout the device to absorb thermal neutrons; (3) small sample chamber; (4) a physically small beam port to limit the beam size and to decrease the likelihood of operator exposure; (5) high density polyethylene and aluminum barriers and walls; and (6) location of the operator controller away from the sample chamber containing the radioactive material. The radiation profile for the devices both in and out of the transport case show relatively low radiation levels that are acceptable per federal regulations for exposure (refer to radiation profile sections). Therefore, based on the information cited above and technical information provided in the application and its attachments, we conclude that the Troxler Models 3241-C and 3241-G Asphalt Content Gauges meet and exceed the requirements to be manufactured and distributed as specifically licensed devices pursuant to applicable regulations listed in 15A NCAC 11.

REFERENCES:

The following supporting documents are hereby incorporated by reference into this SS&D registry document:

1. Letter with attachments dated May 10, 1995 and letter with attachments dated January 07, 1997 from Troxler Electronic Laboratories, Inc., the operating and instruction manual for the 3241-C & 3241-G gauges, testing results for the classification of the Type "A" packages, test results from prototype testing carried out on the Models 3241-C & 3241-G, Sealed Source & Device Registry Certificate No. NC-646-D-128-S originally issued on January 08, 1997;
2. Letter with attachments dated February 14, 2006, signed by Stephen A. Browne, Corporate R.S.O.
3. Issued to correct registration number based on electronic message dated July 12, 2006, from Stephen A. Browne, Corporate R.S.O.
4. Administrative correction to page 2.
5. **Letter with attachments dated March 07, 2008, signed by Stephen A. Browne, Corporate R.S.O. and electronic messages with attachments dated March 14 and March 17, 2008 from Stephen A. Browne, Corporate R.S.O.**

**REGISTRY OF RADIOACTIVE SEALED SOURCES AND DEVICES
SAFETY EVALUATION OF DEVICE
(AMENDS IN ITS ENTIRETY)**

NO.: NC-646-D-128-S

DATE: March 20, 2008

PAGE: 9 of 9

DEVICE TYPE: Asphalt Content Gauge

ISSUING AGENCY:

State of North Carolina
Department of Environment and Natural Resources
Radiation Protection Section, Radioactive Materials Branch

Principal Reviewer



J. Marion Eaddy III, Health Physicist

Date: March 20, 2008

Concurrence Reviewer:

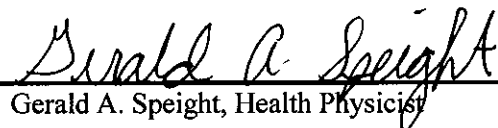

Gerald A. Speight, Health Physicist

Date: March 20, 2008

**REGISTRY OF RADIOACTIVE SEALED SOURCES AND DEVICES
SAFETY EVALUATION OF DEVICE
(AMENDS IN ITS ENTIRETY)**

NO.: NC-646-D-128-S

DATE: March 20, 2008

ATTACHMENT: 1 of 5

DEVICE TYPE: Asphalt Content Gauge

Attachment 1: Three Dimensional View of the 3241-C Series Source Locations

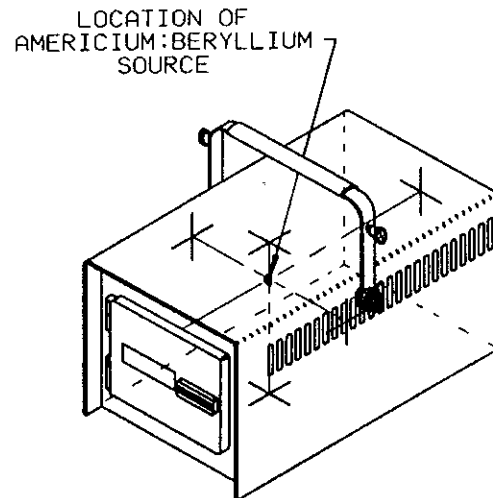
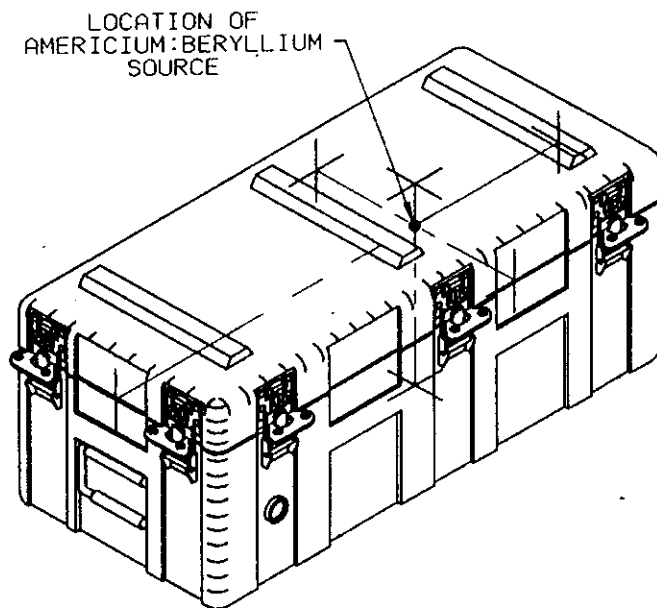

**REGISTRY OF RADIOACTIVE SEALED SOURCES AND DEVICES
SAFETY EVALUATION OF DEVICE
(AMENDS IN ITS ENTIRETY)**

NO.: NC-646-D-128-S

DATE: March 20, 2008

ATTACHMENT: 2 of 5

DEVICE TYPE: Asphalt Content Gauge

Attachment 2: 3241-G Series Gauge Source and Label Locations

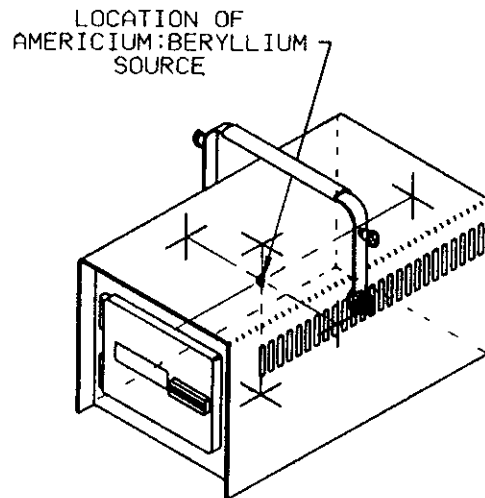
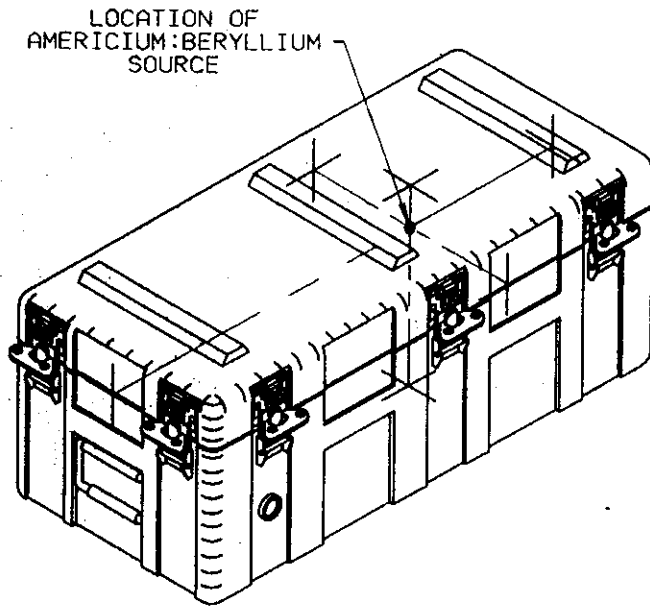

**REGISTRY OF RADIOACTIVE SEALED SOURCES AND DEVICES
SAFETY EVALUATION OF DEVICE
(AMENDS IN ITS ENTIRETY)**

NO.: NC-646-D-128-S

DATE: March 20, 2008

ATTACHMENT: 3 of 5

DEVICE TYPE: Asphalt Content Gauge

Attachment 3: Radiation Profiles for 3241-C (100 mCi) Gauge and Gauge in Plastic Transport Case

Radiation Profile for 3241-C (100 mCi) Gauge

Location	Surface		10 cm		30 cm		1 meter	
	γ	η	γ	η	γ	η	γ	η
Top	3.5	N/A	2.0	N/A	0.15	1.5	<0.1	0.1
Bottom	0.45	N/A	0.35	N/A	<0.1	0.5	<0.1	0.15
Left	1.2	N/A	0.6	N/A	0.1	0.8	<0.1	0.15
Right	1.0	N/A	0.6	N/A	0.2	0.7	<0.1	0.15
Front	1.3	N/A	0.5	N/A	1.5	0.8	<0.1	0.15
Back	0.4	N/A	0.3	N/A	0.1	0.6	<0.1	0.1

Radiation Profile for 3241-C (100 mCi) Gauge in Plastic Transport Case

Location	Surface		10 cm		30 cm		1 meter	
	γ	η	γ	η	γ	η	γ	η
Top	0.6	N/A	0.5	N/A	0.2	0.85	<0.1	0.1
Bottom	0.35	N/A	0.30	N/A	0.15	0.45	<0.1	0.1
Left	<0.1	N/A	<0.1	N/A	<0.1	0.2	<0.1	<0.1
Right	0.4	N/A	0.25	N/A	0.15	0.4	<0.1	<0.1
Front	0.5	N/A	0.25	N/A	0.12	0.45	<0.1	<0.1
Back	0.55	N/A	0.30	N/A	0.1	0.5	<0.1	0.15

Notes:

1. Radiation measurements were for a gauge containing a nominal 100 millicurie Americium 241 source.
2. All radiation measurements are in millirems per hour.
3. Gamma (γ) measurements were obtained with a Ludlum 14C survey meter, calibrated April, 1996.
4. Neutron (η) measurements were obtained with a Nuclear Research Corp. Model NP-2 survey meter, calibrated December 1995
5. Orientation of the gauge in the transport case is as follows:
 - a. Top of the gauge to top of case;
 - b. Front of gauge to right side of case; and,
 - c. Right side of gauge to front of case.

**REGISTRY OF RADIOACTIVE SEALED SOURCES AND DEVICES
SAFETY EVALUATION OF DEVICE
(AMENDS IN ITS ENTIRETY)**

NO.: NC-646-D-128-S

DATE: March 20, 2008

ATTACHMENT: 4 of 5

DEVICE TYPE: Asphalt Content Gauge

Attachment 4: Radiation Profiles for 3241-C (300 mCi) Gauge and Gauge in Plastic Transport Case

Radiation Profile for 3241-C (300 mCi) Gauge

Location	Surface		10 cm		30 cm		1 meter	
	γ	η	γ	η	γ	η	γ	η
Top	6	N/A	2.5	N/A	0.35	2.5	<0.1	0.45
Bottom	1.5	N/A	0.8	N/A	0.30	1.5	<0.1	0.30
Left	3.0	N/A	2.0	N/A	0.35	2.0	<0.1	0.30
Right	3.0	N/A	1.7	N/A	0.35	2.0	<0.1	0.35
Front	3.0	N/A	1.6	N/A	0.4	2.0	<0.1	0.30
Back	1.0	N/A	0.7	N/A	0.2	1.6	<0.1	0.25

Radiation Profile for 3241-C (300 mCi) Gauge in Plastic Transport Case

Location	Surface		10 cm		30 cm		1 meter	
	γ	η	γ	η	γ	η	γ	η
Top	1.6	N/A	1.2	N/A	0.3	2.0	0.1	0.3
Bottom	0.85	N/A	0.6	N/A	0.18	1.25	0.1	0.3
Left	0.18	N/A	0.15	N/A	0.15	0.4	<0.1	0.15
Right	1.2	N/A	1.0	N/A	0.2	1.1	0.1	0.3
Front	1.3	N/A	0.72	N/A	0.23	1.4	0.1	0.25
Back	1.2	N/A	0.95	N/A	0.2	1.6	0.1	0.3

Notes:

1. Radiation measurements were for a gauge containing a nominal 300 millicurie Americium 241 source.
2. All radiation measurements are in millirems per hour.
3. Gamma (γ) measurements were obtained with a Ludlum 14C survey meter, calibrated April, 1996.
4. Neutron (η) measurements were obtained with a Nuclear Research Corp. Model NP-2 survey meter, calibrated December 1995
5. Orientation of the gauge in the transport case is as follows:
 - a. Top of the gauge to top of case;
 - b. Front of gauge to right side of case; and,
 - c. Right side of gauge to front of case.

REGISTRY OF RADIOACTIVE SEALED SOURCES AND DEVICES
SAFETY EVALUATION OF DEVICE
(AMENDS IN ITS ENTIRETY)

NO. : NC-646-D-128-S

DATE: March 20, 2008

ATTACHMENT: 5 of 5

DEVICE TYPE: Asphalt Content Gauge

Attachment 5: Radiation Profiles for 3241-G Gauge and Gauge in Plastic Transport Case

Radiation Profile for 3241-G (100 mCi) Gauge

Location	Surface		10 cm		30 cm		1 meter	
	γ	η	γ	η	γ	η	γ	η
Top	2.5	N/A	1.1	N/A	0.25	2.0	<0.1	0.25
Bottom	0.5	N/A	0.4	N/A	0.4	0.6	<0.1	0.10
Left	0.7	N/A	0.6	N/A	0.1	0.75	<0.1	0.15
Right	0.7	N/A	0.4	N/A	0.1	0.75	<0.1	0.15
Front	0.7	N/A	0.4	N/A	0.15	0.8	<0.1	0.15
Back	0.35	N/A	0.35	N/A	0.15	0.55	<0.1	0.15

Radiation Profile for 3241-G (100 mCi) Gauge in Plastic Transport Case

Location	Surface		10 cm		30 cm		1 meter	
	γ	η	γ	η	γ	η	γ	η
Top	0.5	N/A	0.35	N/A	0.1	0.8	0.1	0.15
Bottom	0.25	N/A	0.22	N/A	0.1	0.45	0.1	0.1
Left	<0.1	N/A	<0.1	N/A	<0.1	0.15	<0.1	<0.1
Right	0.35	N/A	0.25	N/A	<0.1	0.45	<0.1	0.1
Front	0.3	N/A	0.25	N/A	0.15	0.6	<0.1	0.1
Back	0.4	N/A	0.25	N/A	0.1	0.6	<0.1	0.1

Notes:

1. Radiation measurements were for a gauge containing a nominal 100 millicurie Americium 241 source.
2. All radiation measurements are in millirems per hour.
3. Gamma (γ) measurements were obtained with a Ludlum 14C survey meter, calibrated April, 1996.
4. Neutron (η) measurements were obtained with a Nuclear Research Corp. Model NP-2 survey meter, calibrated December 1995
5. Orientation of the gauge in the transport case is as follows:
 - a. Top of the gauge to top of case;
 - b. Front of gauge to right side of case; and,
 - c. Right side of gauge to front of case.