



QSA Global, Inc.
40 North Avenue
Burlington, MA 01803
Telephone: (781) 272-2000
Toll Free: (800) 815-1383
Facsimile: (781) 359-9191

QSA Global Inc. Regulatory/Health Physics – Burlington, MA

Information Regarding Special Form Certificate USA/0733/S-96 for Capsule Codes X130/4

Special form certificate GB/145/S-96 for the X130/4 capsule is now covered by Special Form Certificate USA/0733/S-96 which now approves the source as meeting the requirements of special form radioactive material.

Important Note:

To ensure compliance with the current edition of IAEA Regulations for the Safe Transport of Radioactive Material ONLY X130/4 capsules that were manufactured on or after 15 July 1981 and conform to the requirements of the Special Form Certificate USA/0733/S-96 are approved as Special Form Radioactive Material.

Lori Podolak

10 April 2006



U.S. Department
of Transportation
**Pipeline and
Hazardous Materials
Safety Administration**

**IAEA CERTIFICATE OF COMPETENT AUTHORITY
SPECIAL FORM RADIOACTIVE MATERIALS
CERTIFICATE USA/0733/S-96, REVISION 0**

400 Seventh Street, S.W.
Washington, D.C. 20590

This certifies that the source described has been demonstrated to meet the regulatory requirements for special form radioactive material as prescribed in the regulations of the International Atomic Energy Agency¹ and the United States of America² for the transport of radioactive material.

1. Source Identification - QSA Global, Inc. Model X130/4 (Manufactured on or after July 15, 1981).
2. Source Description - Cylindrical single encapsulation made of monel and beryllium; soldered on one end and tungsten inert gas or laser seal welded on the other end. Approximate outer dimensions are 8.1 mm (0.32 in.) in diameter and 5.3 mm (0.21 in.) in length. Minimum wall thickness is 0.5 mm (0.02 in.). Construction shall be in accordance with attached QSA Global Drawing No. RBA61909, Rev. A.
3. Radioactive Contents - No more than 7.4 GBq (200.0 mCi) of either Plutonium-238, Americium-241, or Curium-244. The Pu-238, Am-241 and Cm-244 are in the form of an oxide or an oxide incorporated into a ceramic matrix.
4. Quality Assurance - Records of Quality Assurance activities required by Paragraph 310 of the IAEA regulations¹ shall be maintained and made available to the authorized officials for at least three years after the last shipment authorized by this certificate. Consignors and consignees in the United States exporting or importing shipments under this certificate shall satisfy the requirements of Subpart H of 10 CFR 71.
5. Expiration Date - This certificate expires on April 30, 2011.

¹ "Regulations for the Safe Transport of Radioactive Material, 1996 Edition (Revised), No. TS-R-1 (ST-1, Revised)," published by the International Atomic Energy Agency(IAEA), Vienna, Austria.

² Title 49, Code of Federal Regulations, Parts 100-199, United States of America.

CERTIFICATE USA/0733/S-96, REVISION 0

This certificate is issued in accordance with paragraph 804 of the IAEA Regulations and Section 173.476 of Title 49 of the Code of Federal Regulations, in response to the March 06, 2006 petition by QSA Global, Inc., Burlington, MA and in consideration of other information on file in this Office.

Certified By:



Apr 06 2006

(DATE)

 Robert A. McGuire
Associate Administrator for Hazardous Materials Safety

Revision 0 - Original issue.

Item No.	Description	Material	Qty.
1	BODY	MONEL	1
2	LID	MONEL	1
3	WINDOW	BERYLLIUM	1
4	PLUG	TUNGSTEN	1
5	INSERT	STAIN. STL.	1
6	ACTIVE MATERIAL		-
7	ANTI-RATTLE CAPSULE SPRING	STAIN. SPRING STL.	1

REVISIONS				
REV.	ERF #	DESCRIPTION	APPROVALS	DATE
A	1258	INITIAL RELEASE	SEE TITLE	BLOCK

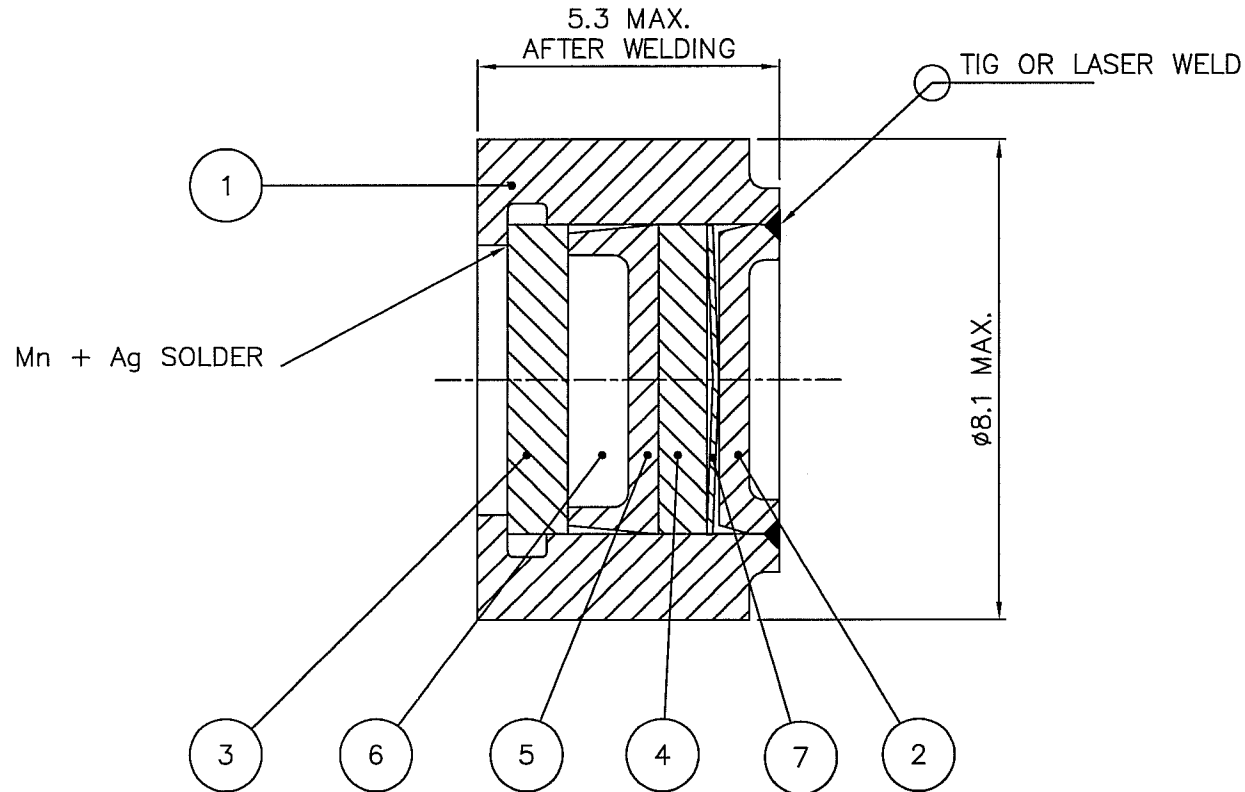

NOTE:
DIMENSIONS ARE IN MILLIMETERS.

APPROVALS	DATE
<i>R. Moore</i>	24 Feb 06
<i>A. P. ...</i>	1 Mar 06

 **QSA GLOBAL**
40 NORTH AVE, BURLINGTON, MA 01803

DESCRIPTIVE
DRAWING

UNLESS OTHERWISE SPECIFIED
DIMENSIONS IN INCHES
TOLERANCES:

FRACTIONS ± 1/8
X.X ± 0.12
X.XX ± 0.06
X.XXX ± 0.020

TITLE ASSEMBLY OF CAPSULE X130/4

SIZE	DWG. NO.	REV
A	RBA61909	A
SCALE:	NTS	SHEET 1 OF 1

ERF #	1258