

TROXLER TRANSPORTATION GUIDE

This guide applies to transportation of Troxler nuclear gauges in the United States.

**Revision 28
(June 2007)**



Troxler Electronic Laboratories, Inc.

3008 Cornwallis Road • P.O. Box 12057

Research Triangle Park, NC 27709

Phone: 1.877.TROXLER

Outside the U.S.A.: +1.919.549.8661

Fax: +1.919.549.0761

www.troxlerlabs.com

Troxler products are protected under U.S. and foreign patents

Copyright © 1999 – 2007

Troxler Electronic Laboratories, Inc.

All Rights Reserved

No part of this manual may be reproduced or transmitted in any form or by any means, electronic or mechanical, including photocopying, recording, or information storage and retrieval systems, for any purpose without the express written permission of Troxler Electronic Laboratories, Inc.

PN 106978
June 2007
Revision 28

TRANSPORTATION GUIDE

OVERVIEW AND APPLICABILITY

This guide is designed to assist Troxler nuclear gauge users in complying with U.S. Department of Transportation (DOT) hazardous material (hazmat) regulations and International Air Transport Association (IATA) Dangerous Goods Regulations. It highlights and explains the major requirements for shipping and transporting portable nuclear gauges in the U.S.

Troxler recommends that persons shipping and transporting nuclear gauges obtain and read the applicable DOT and IATA regulations. The U.S. DOT regulations are published in Title 49 of the Code of Federal Regulations, Parts 100-185 (49 CFR 100-185), which can be viewed online at the U.S. DOT hazmat web site: <http://hazmat.dot.gov>. IATA Dangerous Goods Regulations may be purchased from the IATA online store at: <http://www.iata.org>.

The U.S. DOT HAZMAT regulations apply to all U.S. domestic shipments by all modes of transport. IATA regulations apply to all shipments by air, both international and domestic. When shipping a nuclear gauge by Federal Express®, the gauge must be prepared in accordance with IATA regulations for shipment by air. Throughout this guide, you will see references to the applicable sections of the U.S. DOT regulations given in brackets, such as [§173.410].

The focus of this guide is on preparing nuclear gauges for shipment via common carriers and on transporting gauges as a private carrier. Private carriers generally own the goods (nuclear gauge) being transported and the transportation of the goods is incidental to their regular business activity. A company that owns a nuclear gauge and transports it to and from job sites in the course of business is considered a private carrier. Common and contract carriers, on the other hand, are “for hire” carriers whose primary business is transportation of goods for others.

The major requirements that apply to shipping a gauge via common carrier or transporting a gauge as private carrier include:

- ◆ A current copy of the International Atomic Energy Agency (IAEA) Certificate of Competent Authority (special form certificate) for each source in the gauge must be on file.
- ◆ The gauge must be in a TYPE A package and a copy of the TYPE A package testing results must be on file.
- ◆ The package must be properly marked, labeled, sealed, and inspected prior to each shipment.
- ◆ The package must be properly loaded and secured in the vehicle.
- ◆ Properly completed shipping papers (bill of lading) must be in the transport vehicle and immediately accessible to the driver
- ◆ An Emergency Response Information document must be in the transport vehicle with the shipping papers and immediately accessible to the driver
- ◆ An emergency response phone number must be manned continuously while the gauge is in transit (this service is provided free of charge by Troxler)
- ◆ A certificate of training must be on file for each hazmat employee involved in the shipment, essentially any individual involved in packaging, preparing shipping papers, or transporting a nuclear gauge (training classes are offered by Troxler)

TRAINING

If you own portable nuclear gauges, HAZMAT training is critical to your business. According to the U.S. DOT Office of Hazardous Material Safety:

“More than one-third of the Department's enforcement actions pertaining to violations of the hazardous materials transportation regulations involve the failure of hazmat employers to provide training or maintain test records. In most cases, violations are attributed to failure to provide function specific training. For example, an investigator questions incorrect entries on a shipping paper prepared by a hazmat employee who responds that he was not instructed, nor tested, by his hazmat employer regarding the preparation of shipping papers.”

The regulations define a *hazmat employee* as a person (including a self-employed person) who is employed by a hazmat employer and who:

- ◆ Loads, unloads, or handles hazmat (e.g., a nuclear gauge);
- ◆ Tests, reconditions, repairs, modifies, marks, or otherwise represents packagings as qualified for use in the transportation of hazmat;
- ◆ Prepares hazmat for transportation;
- ◆ Is responsible for safety of transporting hazmat; or
- ◆ Operates a vehicle used to transport hazardous materials.

Each hazmat employer must train and test, certify, and develop and retain records of current training for each hazmat employee (during the period of employment and 90 days thereafter).

Initial hazmat training must be completed within 90 days of employment or change in job function. Before completing training, an employee may only perform hazmat functions under the direct supervision of a properly trained and knowledgeable hazmat employee.

Recurrent training is required at least once every **three years** per U.S. DOT rules.

Relevant training received from a previous employer or source may be used to satisfy the requirements provided a current record of training is obtained from the previous employer or source.

Hazmat employee training must include the following:

- ◆ General awareness/familiarization training
- ◆ Function-specific training
- ◆ Safety training
- ◆ Security awareness training

Training records must include:

- ◆ Hazmat employee's name;
- ◆ Completion date of most recent training;
- ◆ Training Materials (copy, description, or location);
- ◆ Name and address of hazmat trainer; and
- ◆ Certification that the hazmat employee has been trained and tested.

To assist you in meeting these training requirements, Troxler offers both initial and refresher hazmat training courses, including testing and certification. For further information about Troxler training opportunities, please consult our website: <http://www.troxlerlabs.com>.

CERTIFICATE OF COMPETENT AUTHORITY

The sealed sources in Troxler gauges meet the U.S. DOT requirements for classification as Special Form Radioactive Material. Special Form materials are designed and constructed to maintain their physical integrity even under severe accident conditions. For all practical purposes, such materials cannot produce radioactive contamination. The testing requirements that “special form” materials must meet are described in §173.469. Sources meeting these requirements are issued a Certificate of Competent Authority by the International Atomic Energy Agency (IAEA).

A shipper must keep a copy of the IAEA Certificate of Competent Authority (also known as Special Form Certificate) for at least one year after the latest shipment of special form radioactive material [§173.476(a)]. An example of a special form certificate is shown in Appendix F. Please note that these certificates have expiration dates. You must have a current copy in your possession before you can legally ship special form radioactive materials. If shipping a gauge by air, a copy of the special form certificate must be included with the shipment.

Current copies of the certificates can be downloaded from the Troxler web site (www.troxlerlabs.com) or requested by calling Troxler. When requesting a special form certificate, please provide your gauge model number and serial number or the special form certificate number. You can determine the applicable special form certificate numbers by referring to the Troxler gauge certificate.

NOTE

Troxler issues a “gauge certificate” with each gauge. This certificate is sometimes confused with the special form certificate described above. The Troxler gauge certificate gives the gauge model and serial number, owner name and address, and information about the sources in the gauge, including the special form certificate number. The Troxler gauge certificate is not a legally required document for purposes of shipment. However, it is useful when being inspected by either your licensing agency or U.S. DOT, since it provides relevant gauge information.

TYPE A PACKAGES

The type, form, and quantity of radioactive material in most Troxler nuclear gauges requires the use of Type A packaging during transportation. The Troxler gauge shipping case meets all Type A package standards. [§173.410 and §173.412]

Each shipper of a (Specification 7A) Type A package must maintain on file for at least one year after the latest shipment, documentation of the Type A package testing methods and results. This documentation is provided in Appendix A for all Troxler gauges/cases currently manufactured. [§173.415(a)]

MARKING TYPE A PACKAGES

Each Specification 7A package (Troxler shipping case) must be marked on the outside “U.S.A. DOT 7A TYPE A” and “RADIOACTIVE MATERIAL.” [§178.350(b)]

Each package must be marked with the proper shipping name and United Nations identification number (UN ID). [§172.301(a) and (c)]

The U.S. Environmental Protection Agency (EPA) requires notification of serious accidents involving certain quantities of hazardous substances. These “Reportable Quantities” must be identified by the abbreviation “RQ”. For Troxler gauges containing 10 mCi or more of Americium-241 or Americium-241:Beryllium, the letters “RQ” must be marked on the package next to the proper shipping name. [§172.324(b)]

All of the above marking requirements are incorporated into a single label on each Troxler shipping case.

U.S. DOT requires the consignee’s (receiver) or consignor’s (transferor) name and address to be marked on the package, except when the package is transported by highway only and will not be transferred from one motor carrier to another. Therefore, when transporting a gauge to and from a job site by highway, name and address marking is not required. However, if a gauge is transported by a common carrier, name and address marking is required. [§172.301(d)]

LABELING TYPE A PACKAGES

Type A packages containing nuclear gauges are required to have RADIOACTIVE YELLOW-II hazard labels affixed to opposite sides (not top or bottom) near the proper shipping name marking. The following information must be entered on the labels in legible printing with a durable weather-resistant means of marking [§172.403(g)]:

- ◆ **Contents** – the name of the radionuclide(s) in the package (e.g., Cs-137 and Am-241:Be)
- ◆ **Activity** – the activity of the radioactive materials expressed in appropriate SI units, e.g., megabecquerels (MBq), gigabecquerels (GBq).
- ◆ **Transport Index** (for YELLOW-II or YELLOW-III labels only) – the maximum radiation level at one meter from the surface of the package in millirem/hour. See Appendix G for a list of TI values for Troxler gauges.

Type A packages containing nuclear gauges are not allowed on passenger-carrying aircraft. When offered for transport by air, including Federal Express, nuclear gauge packages must bear a CARGO AIRCRAFT ONLY label. [§173.448(f), §172.402(c)]

SECURITY SEALS

Each Type A package must incorporate a feature, such as a seal, that is not readily breakable, and that, while intact, is evidence that the package has not been opened. The seal is required when transporting a gauge to or from a work site, as well as when shipping a gauge via common carrier. You should also lock the gauge before placing it in the case. [§173.412]

INSPECTING PACKAGE BEFORE SHIPMENT

The shipper must inspect each package (gauge shipping case) before each shipment to ensure it is in unimpaired physical condition, except for superficial marks, and that each closure device (hinge, hasp, latch, etc.) is properly installed, secured, and free of defects. [§173.475]

The shipper must also ensure that external radiation and contamination levels are within allowable limits and are consistent with the Transport Index shown on the radioactive labels on the package. If the gauge is in undamaged condition, this requirement may be met by visual inspection of the gauge. However, if the gauge has been damaged then radiation measurements should be made with a survey instrument and a leak test performed on the sealed sources prior to shipping or transporting the gauge.



WARNING

Do not ship or transport a gauge with a sliding block that is not fully closed.

SECURING PACKAGES IN VEHICLE

Any package of radioactive material must be secured against movement within the transport vehicle under conditions normally incident to transportation. [§177.834(a) and §173.448]

MINIMUM SEPARATION BETWEEN PACKAGES AND PEOPLE

Packages bearing RADIOACTIVE YELLOW-II or YELLOW-III labels are not to be carried in compartments occupied by passengers. These packages must be kept a minimum distance away from vehicle occupants, based on the transport index, as shown in the table below. If more than one package is present, the distance (measured from the nearest point on any package) must be based on the total transport index for all of the packages. [§177.842(b)]

Total Transport Index	Minimum Distance (Feet)
0.1 to 1.0	1
1.1 to 5.0	2
5.1 to 10.0	3
10.1 to 20.0	4
20.1 to 30.0	5
30.1 to 40.0	6
40.1 to 50.0	7

For example, a Troxler 3440 gauge with a TI of 0.6 must be kept at least 1 foot away from the driver or passengers. Two Troxler 3440s with a combined TI of 1.2 must be kept at least 2 feet from the driver or passengers.

SHIPPING PAPER PREPARATION AND RETENTION

Shipping paper examples are shown in Appendices B, C, D, and E. Shipping papers must include:

- ◆ UN identification number: UN 3332
- ◆ Proper shipping name: "Radioactive material, Type A package, special form"
- ◆ Hazard class: 7
- ◆ The letters "RQ" for reportable quantities of material if package contains 10 mCi or more of Am-241
- ◆ Radionuclide names: See Appendix G to determine nuclides for your gauge
- ◆ Activity: See Appendix G to determine activities for your gauge
- ◆ Label category: Radioactive Yellow-II
- ◆ Transport index (dose rate in mrem per hour at 1 meter): See Appendix G to determine TI for your gauge
- ◆ The words "Cargo Aircraft Only" if the package is offered for transport by air
- ◆ Emergency telephone number: 919-549-9539
- ◆ Date of acceptance by carrier (i.e., the shipment date)

Shippers and carriers must retain a copy of the shipping papers, or an electronic image thereof, for a period of 2 years after the date the hazardous material is accepted by a carrier. An electronic image includes an image transmitted by fax machine, an image on the screen of a computer, or an image generated by an optical imaging machine. The copy (paper or electronic) must be accessible at or through the principal place of business and immediately available upon request by an authorized official of federal, state, or local government. [§172.201(e)]

Private carriers who use the same shipping paper for multiple shipments of the same hazardous material may retain a single copy of the permanent shipping paper, instead of a copy for each shipment made, if the carrier also retains a separate record of each shipment made, including:

- ◆ Shipping name (proper shipping name)
- ◆ Identification number (UN identification number)
- ◆ Quantity transported (activity in the shipment)
- ◆ Date of shipment

SHIPPER'S CERTIFICATION

For any shipment offered for transport by common carrier, the shipping papers must include a signed and dated shipper's certification statement:

"This is to certify that the above-mentioned materials are properly classified, described, packaged, marked, and labeled, and are in proper condition for transportation according to the applicable regulations of the Department of Transportation."

For transportation by air, the following statement must be added to the above certification:

"I declare that all of the applicable air transport requirements have been met."

No certification is required for a hazardous material transported by motor vehicle by a private carrier if the material will not be reshipped or transferred to another carrier (i.e., no certification is required when a gauge is transferred to and from a job site in a Company vehicle). [§177.204]

SHIPPING PAPER ACCESSIBILITY

When transporting hazmat by motor vehicle, the driver must ensure that the shipping papers are readily available to, and recognizable by, authorities in the event of an accident or inspection. The shipping paper must be clearly distinguished, if it is carried with any other papers, by either tabbing it or by having it appear first in the stack of papers.

When the driver is at the vehicle's controls, the shipping paper must be within immediate reach while the driver is restrained by the lap belt. The paper must be either readily visible to a person entering the driver's compartment (e.g., on the seat next to the driver) or in a holder which is mounted to the inside of the door on the driver's side of the vehicle.

When the driver is not at the controls of the vehicle, the shipping papers must be on the driver's seat or in a holder which is mounted to the inside of the door on the driver's side of the vehicle. [§177.817(e)]

EMERGENCY RESPONSE INFORMATION

An emergency response information sheet must accompany the shipment of a nuclear gauge. This document must be in the transport vehicle and immediately accessible to the driver during transportation on a public highway. Troxler includes a copy of this document with each gauge. An example of an emergency response information sheet is shown in Appendix E. [§172, Subpart G]

EMERGENCY RESPONSE PHONE NUMBER

A 24-hour emergency response telephone number must be provided on the shipping paper. This number must be manned continuously, while the gauge is in transit, by someone who is knowledgeable of the hazards and characteristics of the hazardous material being shipped, has comprehensive emergency response and accident mitigation information for that material, or has immediate access to a person who possesses such knowledge and information. Troxler currently provides this service to Troxler gauge users at no charge (**919-549-9539**). [§172, Subpart G]

ACCIDENT NOTIFICATION REQUIREMENTS

Notify your licensing agency as soon as practical after a reportable incident. You are also required by §171.15 to notify, at the earliest practical moment, the **U.S. DOT at 1-800-424-8802** of an accident that occurs during the course of transportation (including loading, unloading, and temporary storage) in which fire, breakage, spillage, or suspected contamination occurs involving shipment of radioactive material.

EXCEPTED PACKAGES

Some Troxler nuclear gauges may be shipped as excepted packages, including Models 3660, 4301, and 4302. Excepted Packages are not subject to the specification packaging, marking, labeling and shipping paper requirements described above for Type A packages. Excepted packages are subject to the following requirements:

- ◆ The outside of the package must show the full name and address of the shipper and consignee.
- ◆ The outside of the package must be marked with the UN ID number: "UN 2911"
- ◆ For shipment by air, the package must be must be labeled with the Radioactive Material, Excepted Package label. (IATA 10.7.4.4.3)
- ◆ For shipment by air, the air waybill must state in the "Nature and Quantity of Goods" box "Radioactive material, excepted package, instruments, UN 2911", however, a Shipper's Declaration for Dangerous Goods form is not required. (IATA 10.8.8.3)

Shippers and carriers of excepted packages are still subject to the hazmat employee training requirements and accident notification requirements of the hazardous material regulations.

APPENDIX A

TESTING RESULTS FOR TYPE A PACKAGES FOR TROXLER GAUGE CASES

INSTRUCTIONS FOR FINDING TYPE A TESTING RESULTS FOR YOUR PACKAGE:

1. Determine your shipping case type by using the drawing below.
2. Find your gauge model number in the first column of the table on the next page.
3. Find the corresponding case in the second column of this row.
4. Gauges that are no longer in production may not be listed. Please contact your Troxler representative or the Troxler corporate headquarters if you need assistance.

TESTING PERFORMED & RESULTS (unless otherwise indicated in footnotes):

- Water Spray:** Subjected the package to a water spray simulating rainfall of approximately two inches per hour for one continuous hour.
 Results: No physical damage to the package was observed, unless otherwise noted in footnotes.
- Vibration:** The package was vibrated with a displacement of 0.1" at approximately 12 Hz for a period of 24 continuous hours.
 Results: No physical damage to the package was observed, unless otherwise noted in footnotes.
- Free Drop:** The package was dropped from a height of four feet onto a non-yielding surface from a position to cause maximum damage to the package.
 Results: The case was scratched due to the abrasiveness of the concrete, but no other physical damage to the package was observed, unless otherwise noted in footnotes.
- Penetration:** The package was placed on a non-yielding surface. A 1-1/4" diameter, 13-pound steel cylinder with a hemispherical end was dropped in the vertical position from a height of 40" onto the package to a point to cause maximum damage to the package.
 Results: No physical damage to the package was observed, unless otherwise noted in footnotes.
- Compression:** Package was placed on a non-yielding surface and subjected to a compressive load of at least 13 kilopascals multiplied by the vertically projected area of the package, in square feet, for 24 continuous hours.
 Results: No physical damage to the package was observed, unless otherwise noted in footnotes.

PACKAGE DRAWINGS:

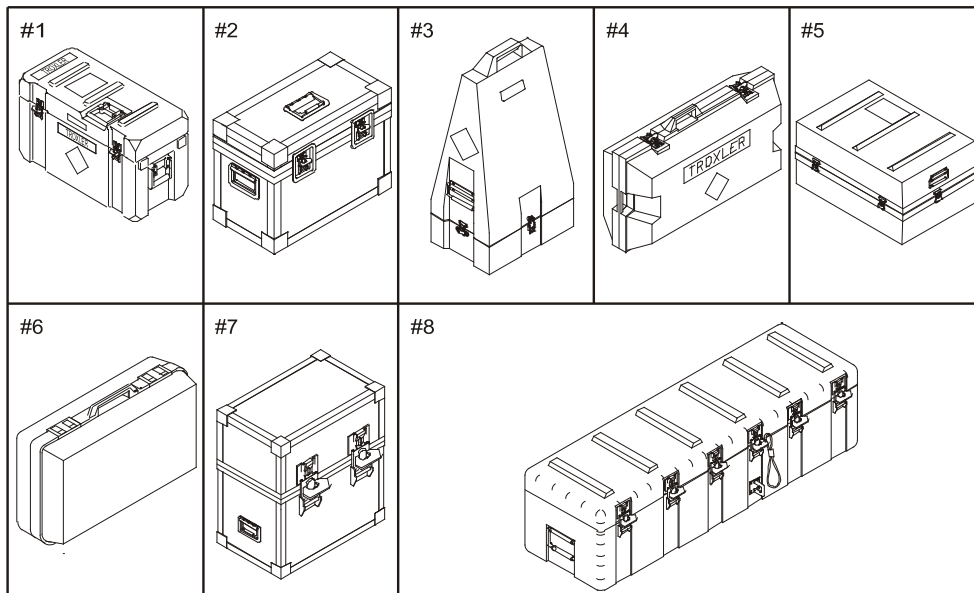

RESULTS OF TESTING

Consult the table below for applicable testing results, as described in the instructions on the previous page.

A [✓] in the table below indicates that the applicable test was performed. The results are on the previous page of this document unless otherwise stated in the referenced footnotes.

GAUGE MODEL	CASE/DRAWING #	WATER SPRAY	VIBRATION	FREE DROP	PENETRATION	COMPRESSION	PACKAGE WEIGHT (lbs)	DATE TEST COMPLETED
3241 SERIES- 3241-A, 3241-B 3241-C, 3241-M 3242	WATER RES/#1	(1)	✓	✓	✓	✓	103, (5)	9/91
	GAUGE ONLY	(1)	✓	✓, (3)	✓, (3)	✓, (2)	55	1/83
3216, 3217, 3218, 3221, 3222	PYRAMID/#3	(1)	✓	✓	✓	✓, (7)	93, (5)	9/91
	PLASTIC/#6	(1)	✓	✓	✓	✓	70, (5)	6/91
3400 SERIES- 3401, 3401-B 3411, 3411-B 3430, 3430-M 3440, 3440-M, 3440-L	WATER RES/#1	(1)	✓	✓	✓	✓	110, (5)	9/91
	TRUNK/#2	(1)	✓	✓	✓	✓	115, (5)	9/91
	PYRAMID/#3	(1)	✓	✓	✓	✓, (7)	93, (5)	9/91
	BLOWMOLD/#4	(1)	✓	✓	✓	✓, (2)	81	5/85
	ABS/#5	(1)	✓	✓	✓	✓	105, (5)	9/91
3430 Plus, 3440 Plus	WATER RES/#1	(1)	✓, (10)	✓	✓	✓	83	1/07
3450, 3451	WATER RES/#1	(1)	✓	✓	✓	✓	96	7/96
4232	WATER RES/#1	(1)	✓, (8)	✓	✓	✓	70, (9)	1/95
4350	WATER RES/#8	(1)	✓	✓	✓	✓	122	3/92
4430	TRUNK/#7	(1)	✓	✓, (3)	✓	✓	107	12/92
4440 SERIES	WATER RES/#1	(1)	✓	✓	✓	✓	120, (5)	9/91
4640	WATER RES/#1	(1)	✓	✓	✓	✓	110, (5)	8/96
	TRUNK/#2	(1)	✓	✓	✓	✓, (2)	93	6/84

Notes:

1. Engineering Evaluation – Water exposure of the magnitude required by regulations would not affect the shielding or containment integrity.
2. Compressive load at date of test was specified as being derived using the “maximum horizontal cross-section of the package,” in place of the “vertically projected area of the package.”
3. Cosmetic damage was observed.
4. Package material was exempt from this test per regulations at the time of testing.
5. Package tested with full weight plus 20 pounds added.
6. Package weight not available (case is no longer in production).
7. Engineering Evaluation - Test not practical due to case geometry.
8. The case was vibrated with a displacement of 1/8" at 15 Hz for a period of 24 continuous hours.
9. The weight of the case and dummy contents as tested was 74 lbs.
10. Engineering Evaluation – Package design and construction are equivalent to other packages in use which have had no vibration-related failures.

Test results were obtained from the most current Type A package testing and evaluation documentation.

APPENDIX B

PRIVATE CARRIER BILL OF LADING FOR A 3400 SERIES GAUGE

This example shows a bill of lading for a 3400 Series gauge transported by private carrier. This document is NOT required to be dated. However, the carrier must retain a record of each shipment made, including shipping name, identification number, quantity transported, and date of shipment.

NOTE

Your source type, source activity, and TI may differ from this example. The “RQ” requirement applies only to sources containing americium-241.

Your Company's Letterhead	
BILL OF LADING	
Shipper:	ABC Paving Company 0000 Road Drive Anywhere, U.S.A.
<u>Qty</u>	<u>Description</u>
1 case	UN3332, Radioactive material, Type A package, Special Form, 7, RQ Cs-137, 0.30 GBq (8.0 mCi) Am-241, 1.48 GBq (40.0 mCi) Radioactive Yellow II Label, TI = 0.3
**** EMERGENCY CONTACT: (919) 549-9539 ****	
Shipper Name (Print):	_____
Shipper Name (Signature):	_____

APPENDIX C

COMMON CARRIER BILL OF LADING FOR A 3400 SERIES GAUGE

This is an example of a bill of lading for a 3400 Series nuclear gauge being shipped by highway.

NOTE

Your source type, source activity, and TI may differ from this example. The “RQ” requirement applies only to sources containing americium-241.

SB Freightways BILL OF LADING

		DATE SHIP DATE	P.O. NO.	SHIPPER NO.	
CONSIGNEE (TO) RED E. WAITING		SHIPPER/CONSIGNOR (FROM) ABC PAVING COMPANY			
DEF PAVING INTERNATIONAL		456 MAIN STREET			
123 DIRT ROAD		ANY OTHER TOWN, U.S.A. 67890			
ANYTOWN, U.S.A. 12345					
PHONE NO.	EMERGENCY RESPONSE NUMBER* (REQUIRED IF HM COLUMN MARKED) 919-549-9539		ROUTE		
(SUBJECT TO CORRECTION)					
Number of Packages	HM *	Kind of Packaging, Description of Articles, Special Marks and Exceptions	Weight (lb)	Class or Rate Ref.	Cube (Optional)
1 case	x	UN3332, Radioactive Material, Type A package,			
		Special Form, 7, RQ			
		Cs-137, 0.30 GBq (8.0 mCi)			
		Am-241, 1.48 GBq (40 mCi)			
		Radioactive Yellow II label, TI = 0.3			
		Dim 35 x 45 x 78 cm			
		Emergency Contact: (919) 549-9539			
THIS IS TO CERTIFY THAT THE ABOVE-NAMED MATERIALS ARE PROPERLY CLASSIFIED, DESCRIBED, PACKAGED, MARKED, AND LABELED AND ARE IN PROPER CONDITION FOR TRANSPORTATION ACCORDING TO THE APPLICABLE REGULATIONS OF THE DEPARTMENT OF TRANSPORTATION.					
SHIPPER/CONSIGNOR WANDA SHIPPITT			CARRIER SB FREIGHTWAYS		
AUTHORIZED SIGNATURE			AUTHORIZED SIGNATURE		
DATE			DATE		

APPENDIX E

EMERGENCY RESPONSE INFORMATION EXAMPLE

TROXLER NUCLEAR GAUGE EMERGENCY RESPONSE INFORMATION REQUIRED FOR TRANSPORTATION

Call Troxler Electronic Laboratories, Inc. at (919) 549-9539 for Emergency Assistance.

1. PROPER SHIPPING NAME:

- ◆ Radioactive material, Type A package, Special Form, UN3332

POTENTIAL HAZARDS

2. HEALTH HAZARDS

- ◆ Radiation presents minimal risk to lives of persons during transportation accidents.
- ◆ Undamaged packages are safe; damaged packages or materials released from packages can cause external radiation hazards. Contamination is not suspected.
- ◆ Packages (cartons, boxes, drums, articles, etc.) identified as "Type A" by marking on packages or by shipping papers contain non-life endangering amounts. Radioactive sources may be released if packages are damaged in moderately severe accidents.
- ◆ Packages (large and small, usually metal) identified as "Type B" by marking on packages or by shipping papers contain potentially life-endangering amounts. Because of design, evaluation, and testing of packages, life-endangering releases are not expected in accidents except those of utmost severity.
- ◆ Commonly available instruments can detect most of these materials.
- ◆ Water from cargo fire control is not expected to cause pollution.

3. FIRE OR EXPLOSION

- ◆ Packagings can be consumed without content loss from sealed source capsule.
- ◆ Radioactive source capsules and Type B packages are designed to withstand temperatures of 1475 °F (800 °C).

EMERGENCY ACTION

4. IMMEDIATE PRECAUTIONS

- ◆ Priority response actions may be performed before taking radiation measurements.
- ◆ Priorities are life saving, control of fire and other hazards, and first aid.
- ◆ Isolate hazard area and deny entry. Notify Radiation Authority of accident conditions.
- ◆ Delay final cleanup until instruction or advice of Radiation Authority.
- ◆ Positive pressure self-contained breathing apparatus (SCBA) and structural firefighter's protective clothing will provide adequate protection against internal radiation exposure, but not external radiation exposure.

5. FIRE

- ◆ Do not move damaged packages; move undamaged packages out of fire zone.
- ◆ **Small Fires:** Dry chemical, CO₂ water spray or regular foam.
- ◆ **Large Fires:** Water spray, fog (flooding amounts)

6. SPILL OR LEAK

- ◆ **Do not touch damaged packages or spilled material.**
- ◆ Slightly damaged or damp outer surfaces seldom indicate failure of inner container.
- ◆ If source is identified as being out of package, stay away and await advice from Radiation Authority.

7. FIRST AID

- ◆ Use first aid treatment according to the nature of the injury.
- ◆ Persons exposed to special form sources are not likely to be contaminated with radioactive material.

APPENDIX F

SPECIAL FORM CERTIFICATE EXAMPLE



U.S. Department
of Transportation
**Research and
Special Programs
Administration**

400 Seventh St., S.W.
Washington, D.C. 20590

**IAEA CERTIFICATE OF COMPETENT AUTHORITY
SPECIAL FORM RADIOACTIVE MATERIALS
CERTIFICATE NUMBER USA/0620/S, REVISION 0**

This certifies that the source described has been demonstrated to meet the regulatory requirements for special form radioactive material as prescribed in the regulations of the International Atomic Energy Agency¹ and the United States of America² for the transport of radioactive materials.

1. Source Identification - AEA Technology QSA, Inc. Model number X.1188.
2. Source Description - Single encapsulation made of stainless steel and tungsten inert gas or laser seal welded. Minimum wall thickness is 0.48 mm (0.02 in.). Approximate outer dimensions are 10.1 mm (0.40 in.) in diameter and 9.7 mm (0.38 in.) in length. All sources shall be constructed and maintained in accordance with attached AEA Technology QSA, Inc. Drawing number RBA61869, Rev. A.
3. Radioactive Contents - No more than 74 GBq (2.0 Ci) Americium-241 oxide mixed with Beryllium and pressed into a solid pellet.
4. Quality Assurance - Records of Quality Assurance activities required by Paragraph 310 of the IAEA regulations¹ shall be maintained and made available to the authorized officials for at least three years after the last shipment authorized by this certificate. Consignors and consignees in the United States exporting or importing shipments under this certificate shall satisfy the requirements of Subpart H of 10 CFR 71.
5. Expiration Date - This certificate expires April 1, 2008.

This certificate is issued in accordance with paragraph 804 of the IAEA Regulations and Section 173.476 of Title 49 of the Code of Federal Regulations, in response to the petition and information dated January 17, 2003 and March 18, 2003 submitted by AEA Technology QSA, Inc., Burlington, MA, and in consideration of other information on file in this Office.

Certified by:

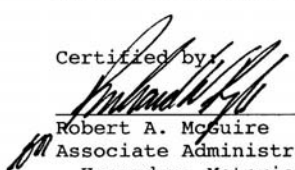
Robert A. McGuire
Associate Administrator for
Hazardous Materials Safety

APR - 8 2003

(DATE)

Revision 0 - Original issue.

1 "Regulations for the Safe Transport of Radioactive Material, 1996 Edition (Revised), No. TS-R-1 (ST-1, Revised)," published by the International Atomic Energy Agency (IAEA), Vienna, Austria.

2 Title 49, Code of Federal Regulations, Parts 100 - 199, United States of America.

APPENDIX G

TRANSPORT INDEXES FOR TROXLER GAUGES

The Transport Index (TI) for a nuclear gauge is defined as the dose rate (mrem/h) one meter from the shipping case.

1. Determine your case type using the case drawings (see page 11).
2. Find your gauge model number in the first column of the table below.
3. Find the corresponding case in the second column of this row.
4. If the gauge was manufactured with different source activities or sources, find this information in the third column.
5. The fourth column provides the TI for each gauge, case, and source combination.
6. Gauges that are no longer in production may not be listed.
7. Please contact your Troxler representative or the Troxler corporate headquarters if you need any assistance.

GAUGE MODEL	NUCLIDES	ACTIVITY	CASE/ DRAWING #	TRANSPORT INDEX (TI)
1351, 1352, 2376	Cs-137	0.3 GBq	TRUNK/#2	0.2
3241-C	Am-241	3.7 GBq	WATER RES/#1	0.1
	Am-241	11.1 GBq	WATER RES/#1	0.5
3241-M	Cf-252	3.7 MBq	WATER RES/#1	0.1
3216, 3217, 3218	Am-241	1.48 GBq	PLASTIC/#6	0.1
			PYRAMID/#3	0.1
3242	Cf-252	3.7 MBq	WATER RES/#1	0.4
3401	Am-241 Cs-137	1.48 GBq 0.3 GBq	WATER RES/#1 or BLOWMOLD/#4	0.4
			TRUNK/#2, PYRAMID/#3, or ABS/#5	0.1
3411	Am-241 Cs-137	1.48 GBq 0.3 GBq	WATER RES/#1	0.5
			TRUNK/#2, PYRAMID/#3, or ABS/#5	0.1
			BLOWMOLD/#4	0.4
3430	Am-241 Cs-137	1.48 GBq 0.3 GBq	WATER RES/#1	0.3
3430M, 3440M	Cs-137 Cf-252	0.3 GBq 2.22 MBq	WATER RES/#1	0.6
3440	Am-241 Cs-137	1.48 GBq 0.3 GBq	WATER RES/#1	0.6
			TRUNK/#2	0.5
3440-L	Am-241 Cs-137	0.56 GBq 0.3 GBq	WATER RES/#1	0.4
3430 Plus, 3440 Plus	Am-241 Cs-137	1.48 GBq 0.3 GBq	WATER RES/#1	0.3
3450, 3451	Am-241 Cs-137	1.48 GBq 0.3 GBq	WATER RES/#1	0.3
4232	Cf-252	3.7 MBq	WATER RES/#1	0.4
4350	Am-241 Cs-137	0.15 GBq 0.3 GBq	WATER RES/#8	0.2
4430	Am-241 Cf-252	0.15 GBq 2.22 MBq	TRUNK/#7	0.1
4440 SERIES	Co-60	2.22 MBq	WATER RES/#1	0.1
	Cf-252	1.11 MBq		
4545	Cs-137	0.3 GBq	TRUNK/#2	0.2
4640 SERIES	Cs-137	0.3 GBq	WATER RES/#1 or TRUNK/#2	0.2